



THE FUTURE IS CAST

LOW ROLLING RESISTANCE

High quality wheels, rollers and ball bearings



ERGONOMIC HANDLE DESIGN

Loop design for comfort and safety

NEW ONE-PIECE HYDRAULIC PUMP

New design improves performance and reliability



PROTECTIVE HANDLE BUMPER

Protects pump piston from wall impact

HIGH PERFORMANCE FRAME

Solid construction finished in durable powder coating



ENTRY SLIDE AND EXIT ROLLERS

Fork tip design provides smooth pallet transition

LIFFRITE®



**THE NEW TITAN SERIES
HAND PALLET TRUCK FROM LIFT-RITE.**

An all new hydraulic pump design is the engine driving the Titan Series. The pump body is cast in one piece to keep oil in the pump and off your floor. A new lowering valve cartridge provides superior operator lowering control. A new high quality thrust load ball bearing and plate equipped with grease fittings makes load steering easier than ever before.

2 YEAR PUMP WARRANTY

Lift-Rite backs our new pump unit with a full 2 year exclusive warranty.

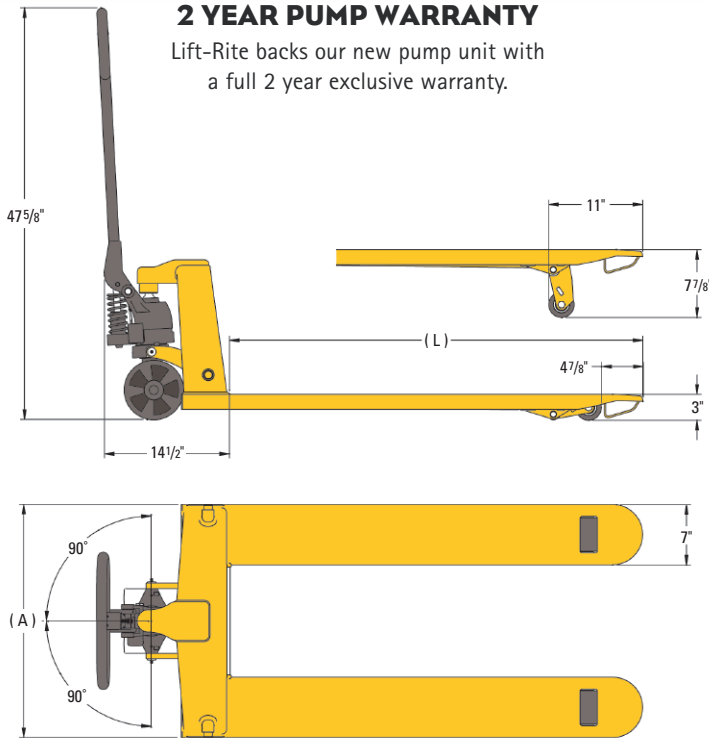

MODEL No.	CAPACITY (LBS.)	FRAME WIDTH (A) (IN.)	FORK LENGTH (L) (IN.)	FORK WIDTH (IN.)	WEIGHT (LBS.)
LCR55270036	5,500	27	36	7	147
LCR55270042	5,500	27	42	7	157
LCR55270048	5,500	27	48	7	167
LCR55205036	5,500	20.5	36	7	142
LCR55205042	5,500	20.5	42	7	147
LCR55205048	5,500	20.5	48	7	152

Due to LIFT-RITE'S continuing product development program, specifications are subject to change without notice. Contact your authorized LIFT-RITE dealer to confirm the most recent specifications.



Lift-Rite Inc., 55 Walker Drive, Brampton, Ontario, L6T 5K5
Phone (905) 456-2603 • Fax (905) 456-1383 • Web www.lifrite.com